



New Zealand
IoT Alliance

IoT Spectrum in New Zealand

BRIEFING
PAPER

Spectrum available in New Zealand for IoT Systems

Published: May 2019

PREPARED BY THE IOT TECHNICAL SPECTRUM WORKING
GROUP OF THE NEW ZEALAND IOT ALLIANCE



CONTENTS

1. Executive Summary	3
2. Introduction	3
The New Zealand IoT Alliance	4
Background	4
3. Licensing Arrangements in New Zealand	4
Management Rights and Spectrum Licensing	4
Radio Licensing	5
General User Licensing	5
Satellite Licensing	5
4. IoT Technologies	6
3GPP Technologies	6
Sigfox	7
LoRaWAN	7
Satellite Technologies	8
5. IoT Spectrum in New Zealand	9
Licensed Spectrum	9
General User Spectrum	10
Satellite Systems	11
International Comparison of Spectrum	12
Licensed Spectrum	12
RSM Spectrum Outlook and Allocations	12
6. Equipment Compliance	13
7. Conclusion	14

This briefing paper was prepared by the IoT Technical Spectrum Working Group which is part of the New Zealand Internet of Things Alliance (IoT Alliance). The New Zealand IoT Alliance was formed in 2017 to actively contribute to the prosperity of New Zealand through accelerating the uptake of IoT. The New Zealand IoT Alliance is a member of the New Zealand Tech Alliance.

1. EXECUTIVE SUMMARY

A June 2017 report by the New Zealand Internet of Things Alliance (IoT Alliance) which explored New Zealand's state of readiness for IoT estimated a potential net benefit of \$2.2 billion for the New Zealand economy over 10 years across common IoT applications. The report identified radio spectrum as an infrastructure enabler for IoT, and therefore it is important that sufficient IoT spectrum is available for New Zealand to see this benefit from IoT.

This paper provides an introduction to the radio spectrum available in New Zealand for IoT networks. Numerous spectrum bands are available for both licensed and 'unlicensed' spectrum from low to high frequencies. This spectrum can cater for range of different IoT networks and applications, and many of these spectrum bands are harmonised with international markets. While licensed spectrum is exclusively available for that licence holder in the described location, unlicensed spectrum generally requires operators to share that spectrum with other IoT and non-IoT users.

The Spectrum Working Group is active and welcomes proposals to enhance and increase the spectrum available for New Zealand's IoT networks.

2. INTRODUCTION

This paper is an introduction to the radio spectrum in New Zealand that is suitable for IoT networks.

The paper describes the radio licensing arrangements in New Zealand, and provides an overview of some of the main IoT technologies used, or likely to be used, in New Zealand. The main body presents the spectrum available for IoT, with comment on how it compares with other countries since international harmonisation is a key part of reducing device costs and providing the widest possible market of products.

The Working Group acknowledges the IoT Alliance Australia's spectrum document¹ as a basis for this paper.

¹ IoT Alliance Australia, Spectrum available for IoT, 2016 <http://www.iot.org.au/wp/wp-content/uploads/2016/12/IoTSpectrumFactSheet.pdf>

THE NEW ZEALAND IoT ALLIANCE

Founded in 2016, the New Zealand IoT Alliance (NZIoT Alliance) is an independent platform for bringing together leaders in IoT technologies, government, academics, and local IoT innovators. The Alliance aims to accelerate IoT innovation by promoting collaboration across industry and government. The Alliance endeavours to identify strategic opportunities for economic growth, and to provide thought leadership for the country around IoT.

BACKGROUND

In June 2017, the NZIoT Alliance released the *Accelerating a Connected New Zealand*² report, which focussed on exploring New Zealand's state of readiness for IoT and areas where the IoT Alliance and the Ministry of Business, Innovation, and Employment (MBIE) can further facilitate IoT developments. Economic analysis by Sapere, an economic consultancy, estimated a potential net benefit of \$2.2 billion in present value terms for the New Zealand economy over 10 years across a mere nine common IoT applications.

While all of these applications indicate an active IoT supply in New Zealand, the demand uptake is slower. The research found that only 14 percent of New Zealand enterprises have deployed an IoT solution.

In the *Accelerating a Connected New Zealand* paper, radio spectrum was identified as an infrastructure and device enabler for IoT. For New Zealand to really benefit from the economic analysis, sufficient spectrum dedicated IoT infrastructure would be required.

To achieve the mass IoT adoption and the full potential economic benefit to New Zealand, a range of spectrum is required; licensed and 'unlicensed' spectrum from low to high frequency bands. Such spectrum would be tailored for a range of different IoT applications and requirements.

3. LICENSING ARRANGEMENTS IN NEW ZEALAND

The three types of licences allowed by Radio Spectrum Management (RSM)³ are:

- Spectrum licences
- Radio licences
- General user licences

MANAGEMENT RIGHTS AND SPECTRUM LICENSING

In New Zealand, Management Rights and spectrum licences are used for high-demand parts of the radio spectrum. All of the New Zealand commercial mobile broadband networks own, or have access to, Management Rights. Management Right holders are able to manage their spectrum to meet their, or other parties', needs (generally by commercial arrangements). RSM set basic technical parameters of Management Rights to allow adjacent users of the radio spectrum to work together. Management Rights are technology neutral, allowing Management Right holders to deploy their choice of technology, without requiring RSM permission to refarm spectrum. Management Right holders will generally set in-band technical conditions to allow for deployment of specific technologies; for example choosing when and where to deploy either 2G, 3G, 4G or 5G cellular systems.

² New Zealand IoT Alliance, *Accelerating a Connected New Zealand*, 2018 <https://iotalliance.org.nz/resources/sector-report/>

³ Radio Spectrum Management (RSM) is a branded business unit of the Ministry of Business, Innovation, and Employment. <https://www.rsm.govt.nz/>

Management Right holders, however, must issue spectrum licences to permit transmission of radio waves. In New Zealand, cellular operators typically issue spectrum licences to themselves. This provides exclusivity of the bands in question.

Management rights (and therefore spectrum licences) can last for up to 20 years in duration. This provides certainty of investment over the duration of the Management Right. Any decision about renewal of Management Rights is typically made five years before the expiry of the Management Right by the current Minister of Communications.

RADIO LICENSING

Frequency bands that are not in as high demand as cellular bands are allocated under the radio licensing regime. This is an administrative regime on a first come, first served basis. For those wishing to deploy IoT devices, there are a number of telecommand and telecontrol bands set aside in the land mobile bands that can be utilised by IoT network operators. These licences have a rolling five year security of tenure, allowing some exclusivity and commercial certainty to access frequencies.

GENERAL USER LICENSING

General User Licence (GUL) bands differ to licensed spectrum bands as these are not issued to an individual or company user, and do not incur any licence fees, but instead are a shared resource for the common good. Unlike other forms of radio communications licensing (namely radio and spectrum licences) that are issued and used on an individual basis, GUL spectrum does come with a greater chance of interference since it is a shared resource that does not provide any specific interference protection.

Currently, spectrum that is globally freely available in the licensed free bands is in the Industrial Scientific Medical (ISM) bands, which include the 900 MHz band, the 2.4 GHz band, and the 5.8 GHz band. ISM bands are, to a large degree, globally harmonised although the regulatory arrangements can vary. In New Zealand, access to these bands is governed by a number of GUL licences.

RSM has licensing arrangements in place that encourage innovation in machine to machine (M2M) and IoT using GULs. The key GUL for IoT devices is the GUL for Short Range Devices (SRD-GUL). The SRD-GUL has numerous allocations that permit M2M or IoT type operations, including for high latency, low power, low data rate devices requiring high reliability.

SATELLITE LICENSING

Most day-to-day satellite operations are licensed using the licencing arrangements described above. For example, fixed ground stations typically get radio licences, and the use of user terminal equipment in the most popular satellite bands is authorised under GUL licencing.

However, the process for satellite licencing is more complex than the process for licencing other radio systems. In order to licence a satellite (or constellation of satellites), a multi-year international coordination of frequencies is typically required. RSM, in conjunction with the New Zealand Space Agency, can provide detailed advice on the requirements for satellite systems.

4. IOT TECHNOLOGIES

The main IoT technologies in use in New Zealand, or likely to be used, are:

- 3GPP based technologies, including LTE Cat 1, Cat M1 (LTE-M), NB-IoT and EC-GSM-IoT
- Sigfox
- LoRaWAN
- Satellite based technologies

There are several other IoT technologies similar to LoRaWAN and Sigfox, such as Weightless.

A different technology is Ultra Wideband (UWB) IoT, whose sensors use a wide range of channels from 3.5GHz to 6.5GHz and can allow ~10 cm accurate 3D spatial positioning.

This spectrum document focuses on longer distance WAN networks, rather than short range LAN or PAN networks, (for example Zigbee or Bluetooth).

These various technologies are compared in terms of range and bandwidth and are shown in Figure 1.

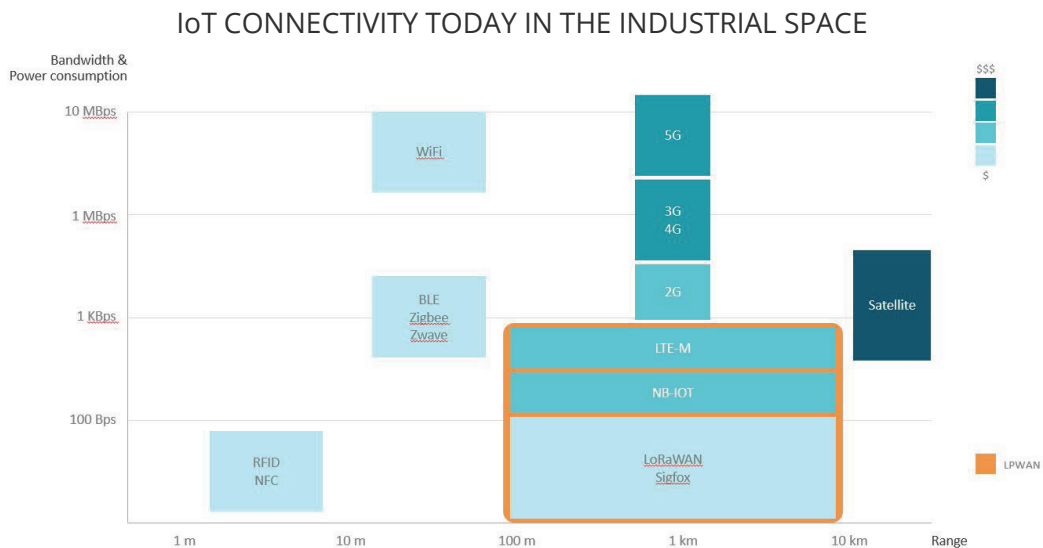

Figure 1: IoT connectivity options for industrial use (source: ThinXtra)

3GPP TECHNOLOGIES

There are a number of new technology standards developed by 3GPP to support different categories of IoT. These new standards are designed to be compatible with existing cellular technologies (for example 2G/GSM, 4G/LTE and 5G), and can be implemented on existing cellular networks with relatively simple upgrades.

The main category likely to be adopted in New Zealand are LTE based technologies, including LTE for Machine-Type Communications (LTE-M) and Narrowband Internet of Things (NB-IoT). Both technologies have been standardised to ensure support by existing 3GPP-compliant cellular networks around the world.

LTE-M and NB-IoT are designed to meet different IoT application needs. LTE-M provides enhanced coverage (compared to existing 2G/3G and 4G standards) and prolonged battery life (up to 10 years), while still providing decent data throughput (up to 1 Mbps download speed) as well as voice services using Voice over LTE (VoLTE). On the other hand, NB-IoT was designed for extreme network coverage

(20 dB more than existing cellular coverage) and even longer battery life (up to 15 years), but at the cost of data speed (in the order of kilobits per second).

Figure 2 shows a comparison of LTE-M and NB-IoT with other cellular technologies.

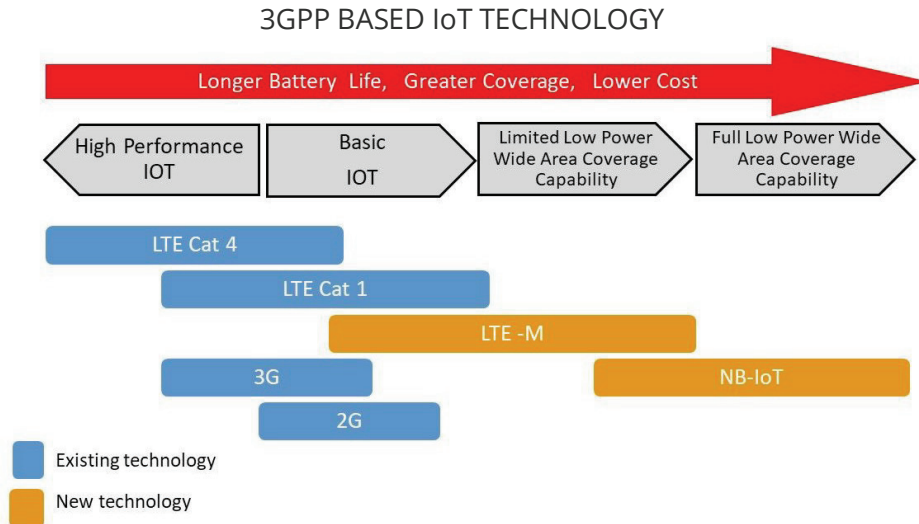

Figure 2: Comparison of NB-IoT, LTE-M and other cellular technologies (source: Vodafone New Zealand)

SIGFOX

Sigfox operates using Differential Binary Phase-Shift Keying (D-BPSK) modulation with an ultra narrow band carrier. In New Zealand each carrier is 600 Hz wide and is transmitted on a pseudo-random frequency over a 192 kHz range from a centre frequency of 920.8 MHz.

Each uplink message consists of up to 26 bytes, of which a maximum 12 bytes is the message payload with a further fixed 14 bytes of protocol overhead data, transferred at 600 bits per second. A downlink message has a message payload of 8 bytes with the additional 14 bytes of protocol data. Downlink messages operate on a random 600 Hz carrier over a 192 kHz bandwidth with a centre frequency of 922.3 MHz.

The robust D-BPSK modulation scheme and low bit rate scheme allows very high base station receiver sensitivity, for example, at 600 bps the base station sensitivity is -134 dBm.

All Sigfox base stations and devices operate on a regulated duty cycle and share the operational frequencies in a 'fair play' way with other RF services.

LoRaWAN

LoRaWAN network architecture is deployed in a star topology in which gateways relay messages between end-devices and a central network server, which is shown in Figure 3 below. The wireless communication takes advantage of the long range characteristics of the LoRa chirp spread spectrum physical layer, allowing a single-hop link between the end-device and one or many gateways. All modes are capable of bi-directional communication, and there is support for multicast addressing groups to make efficient use of spectrum during tasks such as Firmware Over-The-Air (FOTA) upgrades or other mass distribution messages.

The specification defines the device-to-infrastructure (LoRa[®]) physical layer parameters and protocols to provide seamless interoperability between manufacturers. The LoRaWAN specification is developed and maintained by the LoRa Alliance, which consists of an open association of collaborating (paying) members.

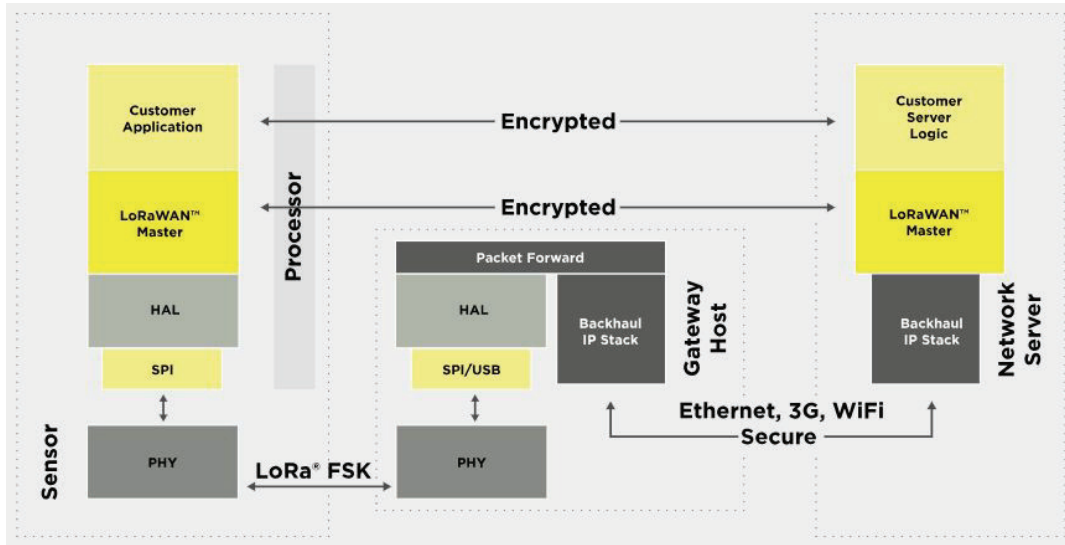

Figure 3: LoRaWAN system diagram (source: LoRa Alliance website)

The LoRaWAN specification also includes a regional parameters specification document that caters for the different regulatory rules in various terrestrial boundaries. This specification describes country specific data-rates, output power limits, maximum payload sizes, and RF channel allocation plans. There are currently 10 discrete LoRaWAN regions defined. In New Zealand, the main public operator uses the AS923 regional plan which occupies the 915-928 MHz bands, and several other LoRaWAN operators use this or the EU868 plan (864 – 870 MHz).

SATELLITE TECHNOLOGIES

Legacy satellite M2M/IoT networks, for example Inmarsat, Iridium and Globalstar in L-band, and Orbcomm in VHF, have been in existence for over a decade now. However, several new start-up small cube satellite operators are now also beginning to launch their new satellite IoT based LEO networks, using the lower cost of entry as a main compelling point for IoT use-cases in remote areas where terrestrial IoT networks are too costly to reach. Some of the operators are shown in Figure 4:

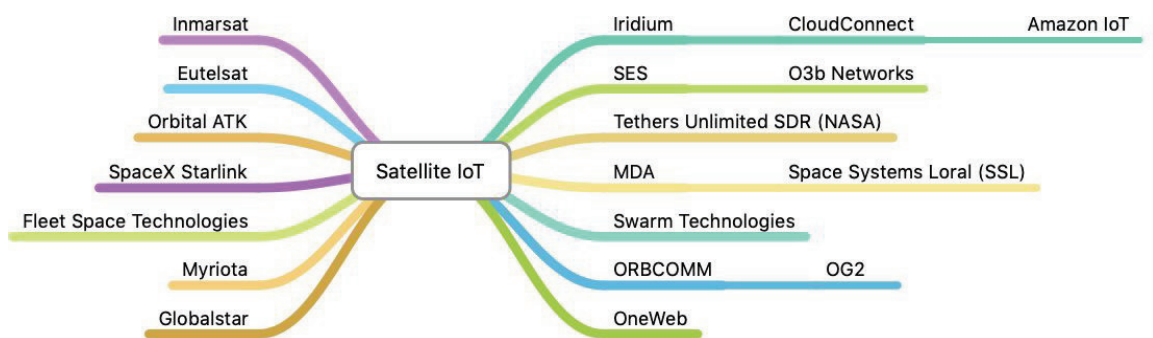

Figure 4: Satellite IoT Operators

Of the newer cube-sat operators, most notable in early launch stages (such as an offer or pre-launch tests) in the Oceania region are Fleet Space Technologies, Myriota, and Swarm Technologies. Early solutions see the use of a terrestrial LoRaWAN based GW, using satellite based uplink and downlinks with LEO message forwarding to ground station terminals and Internet facing messaging platforms. These are mainly using Earth-to-space uplink frequency bands of 399.90 - 400.05 MHz, and space-to-Earth downlink frequency bands of 400.50 - 400.65 MHz, under existing GUL guidelines.

5. IOT SPECTRUM IN NEW ZEALAND

When it comes to spectrum to support M2M and IoT applications in New Zealand, a mix of licensing arrangements and variety of frequency bands may be required to support different IoT use cases.

LICENSED SPECTRUM

All 3GPP based IoT technologies (LTE-M, NB-IoT, EC-GSM) were designed to be an upgrade or extension of existing cellular technologies, and can be considered new features of the GSM/LTE technologies. As such, they are implemented in existing GSM/LTE carriers on frequencies used by the respective GSM/LTE carriers.

In almost all markets, cellular networks use licensed radio spectrum. This allows the most efficient use of spectrum by mobile network operators (MNOs) and minimises interference issues. In New Zealand, MNOs own Management Rights for blocks of identified cellular spectrum and operate their network in these bands. These bands are shown in table 1.

3GPP Band number	Uplink Frequency Range (MHz)	Downlink Frequency Range (MHz)
28	703-748	758-803
5	825-840	870-885
8	890-915	935-960
3	1710-1785	1805-1880
1	1920-1980	2110-2170
40	2300-2370 (TDD ⁴)	
7	2500-2570	2620-2690

Table 1: Cellular bands under Management Rights in New Zealand

5G technology is becoming ready for commercial deployment and will provide its own IoT-centric features. RSM is in the process of identifying additional cellular spectrum for 5G use. Bands currently being considered include 3.4-3.8 GHz and 24.5-29.5 GHz. It is expected that these new frequency bands used by 5G will become part of the IoT ecosystem, with confirmation due sometime in 2019/2020.

⁴ Band 40 is configured for Time Division Duplex (TDD) operation, where the same spectrum is used both uplink and downlink communication.

GENERAL USER SPECTRUM

The table below contains information about the Short Range Device General User Licence including those ISM bands that have been allocated under the International Radio Regulations.

Frequency range	Power	Commentary on use
13.553 - 13.567 MHz	-10 dBW	ISM band
27.950 - 27.300 MHz	0 dBW	ISM band
40.660 - 40.700 MHz	0 dBW	ISM band
433.050 - 434.790 MHz	-16 dBW	433 MHz band, typically used for garage door openers and alarm systems
864 - 868 MHz	6 dBW	Partially harmonised with the European band
915 - 928 MHz	0 dBW	900 MHz allocation. Emissions at the lower end of the band are stricter than Australia however.
920 - 928 MHz	6 dBW	900 MHz high power allocation
2400 - 2483.5 MHz	6 dBW	ISM, bluetooth and core WiFi band
5150 - 5250 MHz	-7 dBW	Indoor use only 5GHz WiFi band
5250 - 5350 MHz	0 dBW	5GHz WiFi band
5470 - 5725 MHz	0 dBW	5GHz WiFi band
5725 - 5875 MHz	6 dBW	5GHz WiFi and ISM band
24 - 24.25 GHz	0 dBW	ISM band
57 - 66 GHz	13 dBW	WiGig band

Table 2 Select Spectrum available for IoT use under the SRD-GUL

In New Zealand there are two blocks of general user spectrum, that to date (2019), have shown the most deployment for IoT connectivity outside of the WiFi bands (being 2.4 and 5 GHz). These bands are the 868 and 900 MHz bands, respectively. Figure 5 shows the comparison of international arrangements between various countries.

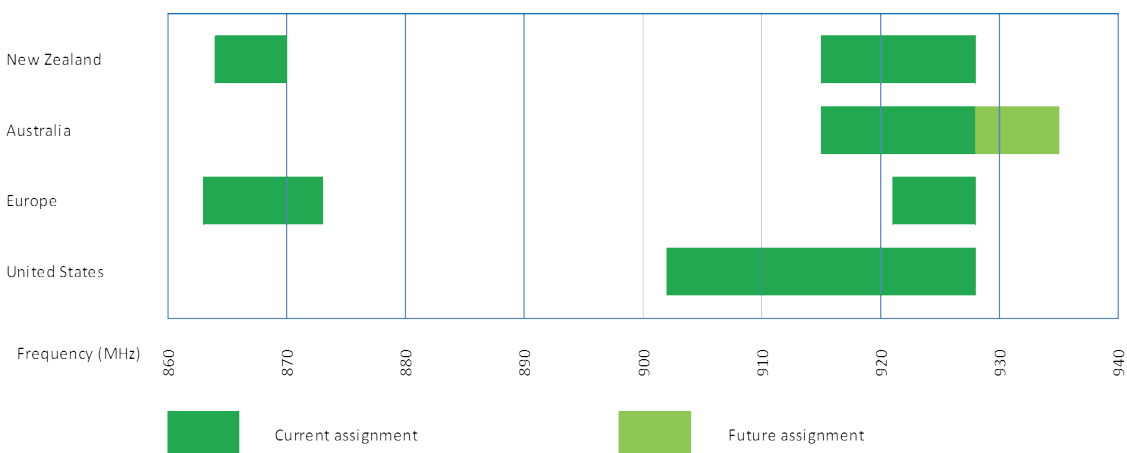

Figure 5: International arrangements in the 800 & 900 MHz bands for IoT

Because of the foundational blocks of spectrum, especially around cellular connectivity, there are a number of issues to consider when comparing availability of spectrum for IoT deployment in New Zealand, and the locations of major equipment suppliers.

864-870 MHz

New Zealand allows 864 - 870 MHz to be used as GUL spectrum, which permits IoT use in this band. Europe, however, has developed arrangements for short range devices in the slightly wider range of 863-876 MHz. Therefore, any devices that use the European '868' band that are brought into New Zealand need to have their range and power of operation confirmed to ensure compatibility with the New Zealand rules. Bounding this GUL spectrum are land mobile services below 864 MHz and cellular services above 870 MHz. The 868-870 MHz portion of the band has further power restrictions to protect the spectrum users above 870 MHz.

915 - 928 MHz

The mix of different cellular solutions in New Zealand has restricted the size of the ISM band to 915-928 MHz. Although Australia has the same ISM band available, the emissions at the lower end of the band in Australia are slightly less restrictive. In the United States, the ISM band is able to operate from 902-928 MHz. This means some solutions that are available in the United States and Australia need to be modified to work in New Zealand.

While Europe has recently made available 915-921 MHz for low duty cycle applications, these arrangements would be ineffectual in New Zealand given the arrangements already in place and range of devices already supported.

928-935 MHz

Australia has recently reviewed its 803-960 MHz band. The result of this review will see changes across the Tasman to extend operation up to 935 MHz. These changes are scheduled to be implemented in 2021. RSM in New Zealand has no current plans to open up 928 - 935 MHz, due to the existing users in this band.

SATELLITE SYSTEMS

Satellite earth station transmitters are also generally covered by the General User Licence (GUL) for satellite services. Information from this GUL is shown in Table 3 below:

Frequency range	Power	Commentary on use
148 - 150.05 MHz	10 dBW	For Mobile Satellite Service
399.9 - 400.5 MHz	-3 dBW	For Mobile Satellite Service
1610 - 1660.5 MHz	20 dBW	For Mobile Satellite Service
14000 - 14500 MHz	56 dBW	For Mobile Satellite Service

Table 3: Spectrum available for IoT use under the SS-GUL

VHF and UHF bands are starting to find uses for IoT, but at the time of writing, there are only a handful of operators who are offering commercial services in New Zealand, such as Orbcomm. There are a few other operators such as Myriota, who are developing services in Australia but have yet to offer services in New Zealand. Services in these bands are typically characterised by very low data rates and high latency connections.

L band services are typically the most IoT friendly services, due to trade off between form factor and power consumption. Iridium, for example, offer small PCB mounted modules for easy integration into IoT devices and base stations.

There appear to be no IoT options in the higher frequency satellite bands such as Ku and Ka bands at the time of writing, despite those bands being available for use.

INTERNATIONAL COMPARISON OF SPECTRUM

As New Zealand is a small market with few mainstream technology manufacturers it has to ensure that spectrum allocations align as much as practicable with other markets. These assignments can occur on a regional or a worldwide basis.

However, in any particular spectrum band there are often a number of different uses internationally. New Zealand's spectrum arrangements are rarely unique, but neither are they necessarily aligned with all international markets. Only overseas equipment from markets that have the same spectrum arrangements as New Zealand are able to be used in New Zealand (and even then, there may be some licence conditions that differ).

LICENSED SPECTRUM

In allocating radio spectrum for mobile technology uses, RSM have mostly followed European practice in the past. More recently, RSM started following Asia Pacific trends, and have encouraged the market to adopt 3GPP standards by adopting 3GPP compliant band plans. The amount of spectrum made available for mobile technologies is considered adequate and allows existing mobile operators to provide competitive mobile service levels compared with international benchmarks.

RSM have traditionally worked closely with the mobile industry to determine the best way to allocate and utilise radio spectrum. It is important that RSM continue to do this in the future to ensure there is sufficient spectrum available for mobile and IoT use, and the spectrum plan is designed to maximise efficiency and minimise potential interference.

RSM SPECTRUM OUTLOOK AND ALLOCATIONS

In the most recent five year spectrum outlook (2017 - 2021), RSM noted that IoT⁵ " is an emerging concept for connecting objects and appliances to the internet." Furthermore, "M2M applications are widely used for transmitting low bit-rate data between devices and systems."

RSM's work action points for IoT connectivity focus on two areas. These being:

- Engaging in the international studies on narrowband and broadband machine communications for IoT under the agenda issue set for WRC-19; and
- RSM temporarily reserving the band 5.875 – 5.925 GHz, subject to the international studies and WRC-19 decisions. This band is likely to be used for connected vehicles and associated infrastructure.

⁵ Ministry of Business, Innovation & Employment, *Five year spectrum outlook 2017-21*, 2016 <https://www.rsm.govt.nz/online-services-resources/pdf-and-documents-library/publications-and-guides/rsm-annual-reports-and-business-plans/rsm-outlook-2017-2021.pdf>

Future IoT Spectrum Allocation

In 2017, RSM consulted on future uses of spectrum vacated after the switch off of analogue television in the upper VHF band. The Minister of Communications reserved 10 MHz of spectrum between 210 - 220 MHz for an IoT testbed. RSM has been tasked in developing the rules and allocation of this band. The band is expected to be initially allocated for three years to allow IoT network operators to test and develop IoT connectivity in the upper part of the VHF spectrum. This is the first dedicated IoT band in New Zealand. The band went live in the first half of 2019.

A future topic for this Working Group is to investigate what spectrum is required to meet expected future IoT demand. While this may require new spectrum allocations for IoT, it should also involve making more efficient use of spectrum already used by IoT networks, including optimisation of General User Licence bands used by IoT.

6. EQUIPMENT COMPLIANCE

In New Zealand, electrical and electronic products on sale or in use must comply with Electromagnetic Compatibility (EMC) Standards. Radio products that are manufactured, imported, distributed, sold, or installed in New Zealand are required to meet radio standards, in addition to licensing and spectrum management requirements.

RSM provide a step by step walkthrough of the compliance that is required, which can be found online⁶. Equipment compliance and device certification is within the scope of IoT Device Certification Working Group, and will be providing more guidance for IOT equipment.

⁶ <https://www.rsm.govt.nz/compliance/supplier-requirements/how-to-ensure-your-products-comply>

7. CONCLUSION

This paper has outlined spectrum that is available for IoT networks in New Zealand. These bands can cater for different types and uses of IoT networks, and many of these spectrum bands are harmonised with international markets for economies of scale.

The Spectrum Working Group of the NZIoTA is active, and proposed topics for study include future IoT spectrum demand and optimising General User Licence bands already used by IoT networks. The Working Group welcomes ideas and proposals to enhance and increase the spectrum available for New Zealand's IoT networks.

Disclaimer

Any opinions and analysis presented in the Briefing Paper are the opinion of the author of the paper, not the opinion of the New Zealand IoT Alliance.

New Zealand IoT Alliance
Level 1, Building C, 14-22 Triton Drive, Auckland 0632, New Zealand
+64 9 394 7964
iotalliance.org.nz
